

HTS6

Operating Manual
Genelec HTS6
Active Subwoofer

GENELEC®

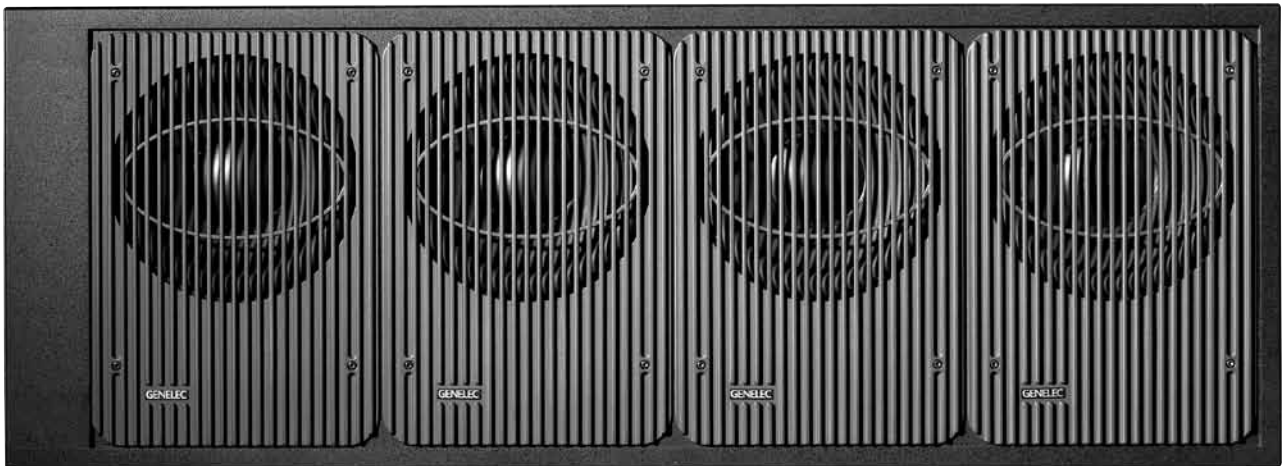



Genelec HTS6 Active Subwoofer

General description

The Genelec HTS6 is a powerful active subwoofer designed specially for high quality digital 5.1 channel Home Theater systems. Its 19 to 120 Hz (± 3 dB) frequency range and 124 dB sound pressure output capability are sufficient to handle the most demanding high SPL applications.

High quality XLR and RCA line level input connectors and adjustable input sensitivity provide easy connection to all types of decoders. Bass roll-off rate and crossover phase can be adjusted to suit different acoustical environments and subwoofer positioning. A "LINK OUT" connector allows coupling two or more subwoofers together when very high sound pressure levels are required.

Installation

Each subwoofer is supplied with a mains cable and an operating manual. Once unpacked, place the subwoofer in a suitable location (For more details see the 'Positioning' section).

Before connecting the audio signals, ensure that all equipment are switched off. Check

that the subwoofer voltage selector switch is set to the correct voltage. Audio input to the subwoofer can be made via balanced XLR or unbalanced RCA connector. We recommend the use of balanced cables and connectors due to their better noise immunity. Do not use both inputs at the same time.

The "LINK OUT" connector can be used for daisy-chaining several subwoofers together when high SPL is required. Simply connect a balanced XLR cable from the "LINK OUT" connector to the "XLR INPUT" connector of the next subwoofer. See section "Using multiple subwoofers".

Once all connections have been made, the subwoofer and main speakers are ready to be powered up.

Positioning in the room

The placement of the subwoofer in the room affects the overall frequency response and sound level of the system dramatically, as at low frequencies the effects of the room are strong. Even a slight change in the subwoofer's location can make a marked difference in the frequency balance and often patient and methodical experimentation and testing is needed to find the optimum placement.

The placement will affect the phase difference between the main monitors and the subwoofer, and also the bass roll-off rate. These effects can be compensated by the use of the controls in the amplifier unit; but we recommend that at first you leave the switches untouched and concentrate on finding the position where the subwoofer gives the smoothest response, and only then use the controls to fine-tune the balance and phase alignment between the subwoofer and the main speakers.

To begin with, place the subwoofer slightly offset from the center of the front wall. The recommended distance to the wall is less than 90 cm / 36" measured from the subwoofer's drivers. This position gives increased acoustic loading (and SPL) due to the proximity of the front wall and floor. Cancellations from the front wall and floor are also avoided. In a multichannel system the main speakers should ideally be positioned symmetrically and at an equal distance from the listening position.

If the frequency balance is not right, try moving the subwoofer slightly to the left or right so that different room modes are excited at different levels. Positioning the subwoofer

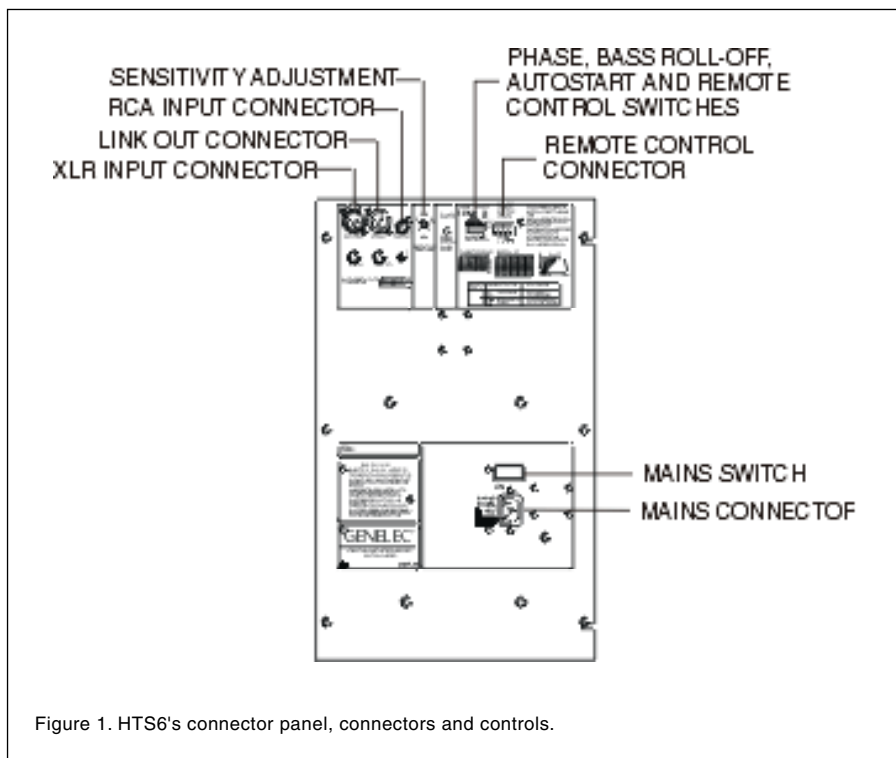

Figure 1. HTS6's connector panel, connectors and controls.

Subwoofer placement	Bass Roll-Off setting
Near to a wall	-2 dB
In a corner	-6 dB
Flush mounted	-2 dB

Table 1. Suggested Bass Roll-Off settings

close to a corner will boost the bass level at lower frequencies and may cause asymmetrical spatial imaging. If you are using two subwoofers, try placing them asymmetrically relative to the side walls. Sometimes moving the subwoofers apart into the front corners helps with problematic rear wall reflections and the loss of mutual coupling is compensated by the bass boost caused by corner positioning.

Although the HTS6 subwoofer is magnetically shielded, they may cause some picture distortion if placed near very sensitive video monitors or computer displays.

Minimum clearances to walls or other objects

The power amplifiers are attached to the lower part of the aluminium grilles, which function as a heatsink. Do not cover the grilles or place the subwoofer so that there is less than 10 centimeters (4") of free space in front of the grilles.

The reflex port and connector panel should always have a clearance of at least 20 centimeters (8") to any objects to ensure proper function of the port and cooling for the electronics attached to the connector panel.

Flush mounting the subwoofer

If the subwoofer is flush mounted into a wall or a cabinet, it is important to ensure unrestricted airflow from the reflex port and cooling for the electronic components. This can be done by making the recess 20 centimeters (8") wider than the subwoofer. Place the subwoofer into the right end of the recess with the drivers' side facing the room. This leaves sufficient 20 centimeters (8") of free space on the connector panel and reflex port side. The height and depth of the recess should not be any bigger than those needed to fit the subwoofer flush with the wall surface.

Setting the input sensitivity

The subwoofer requires input sensitivity alignment to the source to obtain a correctly balanced system. The input sensitivity control is located on the connector panel of the subwoofer. An input voltage of -6 dBu with a -6 dBu input sensitivity setting will produce 100 dB SPL @ 1m in free field. To obtain a 110 dB SPL output an input voltage of +10 dBu is required when the input sensitivity is set to 0 dBu.

Setting the Bass Roll-Off switches

The acoustic response of the subwoofer may have to be matched to the characteristics of the room and the positioning in which it will be used. To adjust the subwoofer to match these characteristics use the "Bass Roll-Off" control switches located on the connector panel. Table 1 provides some suggestions for the "Bass Roll-Off" switch settings. When all roll-off switches are set to "OFF", a flat anechoic response is obtained.

Setting the phase control

Incorrect phase alignment between main monitors and subwoofer causes a drop in the frequency response of the whole system at the crossover frequency. The graphs on the following page (Fig. 4) show the effect of phase difference to the frequency response.

The phase difference between the main speakers and subwoofer at the listening position is dependent upon the position of the subwoofer, so the phase adjustment should be done only after the preferred position is found. Acoustic measuring equipment is required for accurate system alignment. If

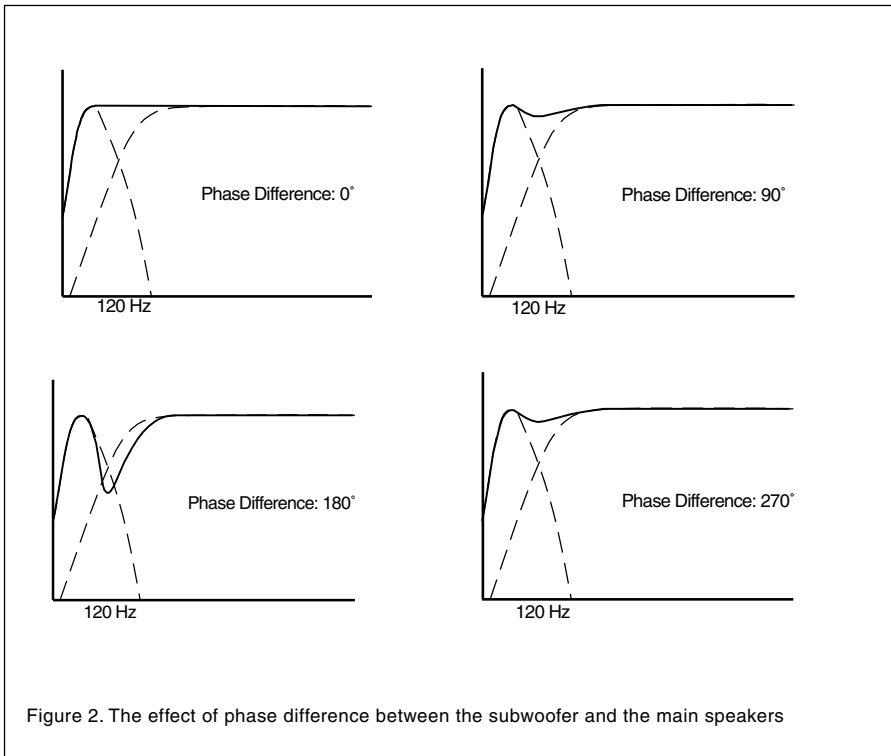

this equipment is not available, the following coarse phase matching can be applied.

Coarse phase adjustment method

Configure the processor so that the main speakers (L, C, R) are set to “small” and check the subwoofer crossover frequency setting on your processor. This setting may be either fixed or variable, consult the operating manual of your processor.

Connect an audio frequency signal generator to one of the front L, C or R input channels used in the system.

Set the frequency generator to the same frequency as the subwoofer crossover frequency on your processor.

If a signal generator is not available, you can use an audio test recording with a suitable range of test frequencies. Mute all other channels and perform the adjustment with only one of the front speakers playing.

Toggle the -180° phase switch ‘ON’ and ‘OFF’ and set it to the position which gives the lowest sound level at the listening position.

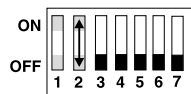

Next toggle the -90° phase switch ‘ON’ and ‘OFF’, and again set it to the position which gives the lowest sound level.

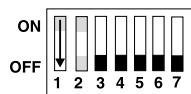

Finally, set the -180° phase switch to the opposite setting.

Using multiple subwoofers

The HTS6 is equipped with a “LINK OUT” connector to provide an easy way of coupling two or more subwoofers together in high SPL applications. Connect a XLR cable from the “LINK OUT” connector of the “master” HTS6 to which the main monitor channels are connected, to the “XLR IN” connector of the other, “slave” subwoofer.

When two subwoofers connected in this way are positioned close to one another, bass level increases by 6 dB. Three subwoofers give an bass SPL increase of 9,5 dB and four subwoofers 12 dB compared to a single subwoofer. Adjust the sensitivity control of all subwoofers in the group to match the SPL level with the main speakersystem. Note that

Remote control type	Pole or contact	Connect to remote control input pin no.
12 V DC remote control	+	1
	-	2
External switch or relay	Contact 1	3
	Contact 2	4
Connect only one remote control unit at a time		

Table 2. Remote control connector pin sequence

the sensitivity setting must be the same on all subwoofers.

Autostart and remote control

“AUTOSTART” and “REMOTE CONTROL” functions described in this chapter are not available on subwoofers sold in the EU.

The HTS6 is equipped with an “AUTO-START” function, which automatically turns the amplifier to “STANDBY” mode if an input signal has not been detected for approximately five minutes, and back to “ON” mode when the signal returns. The function can be deactivated by turning the “AUTOSTART” dip switch to “OFF”. A two-colour LED on the connector panel indicates the amplifier status: green for “ON” and yellow for “STANDBY”.

The amplifier mode can also be switched by a remote control unit connected to the respective inputs on the amplifier. Two pairs of connectors are provided, 1 and 2 for a 12 V DC type remote control, and 3 and 4 for an external switch or relay type control. Do not connect two remote controls to the subwoofer at the same time. Remote control overrides the “AUTOSTART” function.

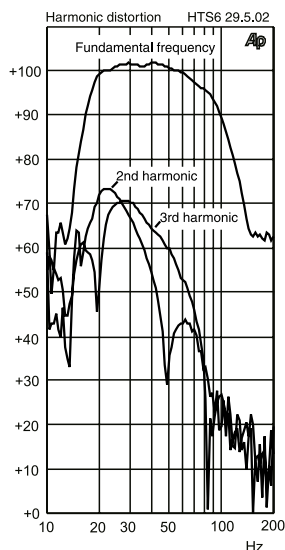

Figure 3. The curves above show the harmonic distortion analysis of the HTS6 in free field. In half space the SPL will be 6 dB higher.

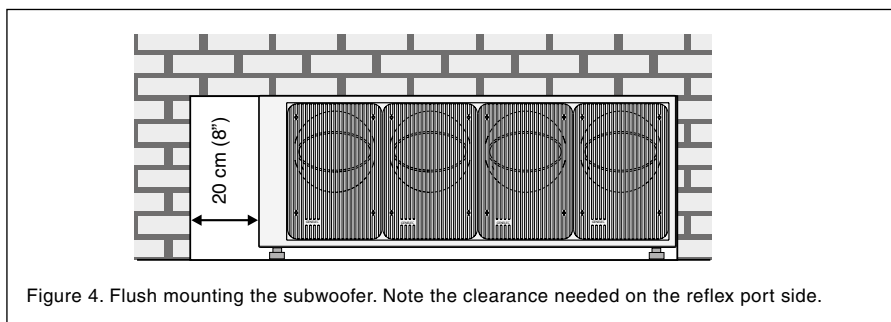

Figure 4. Flush mounting the subwoofer. Note the clearance needed on the reflex port side.

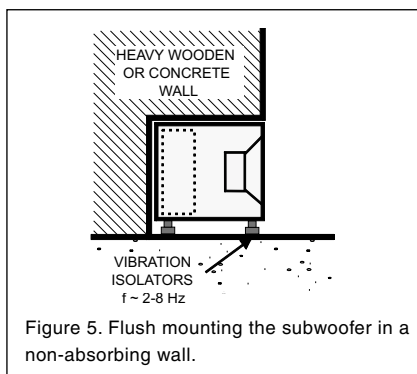

Figure 5. Flush mounting the subwoofer in a non-absorbing wall.

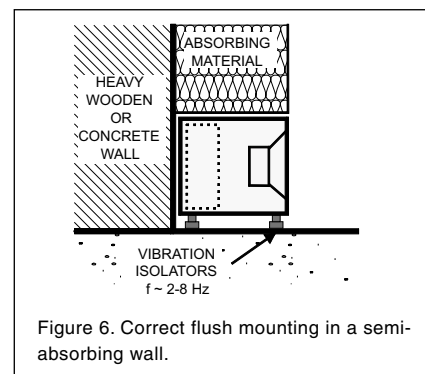

Figure 6. Correct flush mounting in a semi-absorbing wall.

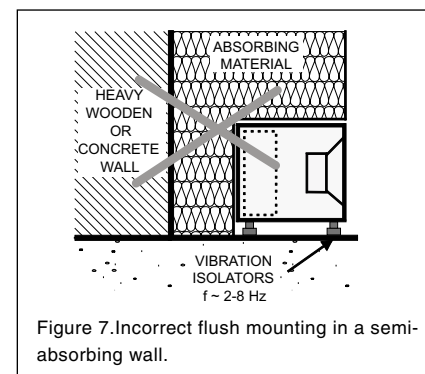

Figure 7. Incorrect flush mounting in a semi-absorbing wall.

Automatic protection circuits

The HTS6 is equipped with protection circuits against speaker driver thermal overload and amplifier overheating. The protection system resets automatically so the user only has to turn the input level down to ensure that it does not reactivate.

Safety considerations

The HTS6 subwoofer has been designed in accordance with international safety standards. However, to ensure safe operation and maintain the unit in safe operating condition, the following warnings and cautions must be observed:

- Do not expose the subwoofer to water or moisture. Do not place any objects filled with liquid, such as vases on the subwoofer or near it.
- Servicing and adjustment must only be performed by qualified service personnel.
- Opening the connector panel is strictly prohibited except by qualified service personnel.

- Always use a mains power connection with protective earth. Failing to do this may lead to personal injury.
- Note that the amplifier is not completely disconnected from the AC mains service unless the mains power cord is removed from the amplifier or the mains outlet

Warning!

This equipment is capable of delivering sound pressure levels in excess of 85 dB, which may cause permanent hearing damage.

Maintenance

No user serviceable parts are inside the amplifier unit. Any maintenance of the unit must only be performed by qualified service personnel.

Guarantee

This product is supplied with a two year guarantee against manufacturing faults or defects that might affect the performance of the unit. Refer to supplier for full sales and guarantee terms.

HTS6 Operating Manual

SYSTEM SPECIFICATIONS	
	HTS6
Free field frequency response (+/- 3 dB)	19 Hz...120 Hz
Maximum short term sine wave SPL output averaged from 30 to 85 Hz, measured in half space at 1 meter	≥ 124 dB SPL
Maximum peak SPL output with random pink noise, measured in half space at 1 meter	≥ 129 dB SPL
Self generated noise level in free field @ 1 m on axis (A-weighted)	≤ 20 dB
Harmonic distortion at @ 1 m on axis in half space 2nd 3rd	@ 105 dB SPL 30 ... 85 Hz ≤ 2 % ≤ 2 %
Drivers	4 x 305 mm (12")
Weight	120 kg (265 lbs)
Dimensions Height Width Depth	524 mm (20 5/8") 1440 mm (56 11/16")* 558 mm (22")

* If the subwoofer is flush mounted into a wall or a cabinet, the recess must be 20 cm (8") wider than the subwoofer to allow sufficient clearance for the reflex port situated at the end of the subwoofer enclosure.

CROSSOVER SECTION	
	HTS6
Subsonic filter (18 dB/octave) below	19 Hz
Upper bandwidth	120 Hz
Crossover slopes Lowpass Highpass	36 dB/octave 12 dB/octave
Midband rejection >400 Hz	≥ 50 dB
Bass roll-off control operating range in 2 dB steps	From 0 to -6 dB @ 20 Hz
Phase matching control in 90° steps	From 0 to -270° @ 85 Hz

AMPLIFIER SECTION	
	HTS6
Short term amplifier output power (Long term output power is limited by driver unit protection circuitry)	1000 W
Amplifier system distortion at nominal output THD	≤ 0.05%
Mains voltage	100/200V or 115/230V
Power consumption (average) Idle Full output	60 VA 1000 VA

INPUT SECTION	
	HTS6
Input connector XLR female pin 1 pin 2 pin 3	gnd + -
Input impedance	10 kOhm balanced
Input level for 100 dB SPL output @ 1 m	Variable from +6 to -12 dBu

LINK OUT CONNECTOR	
	HTS6
Output connector XLR male pin 1 pin 2 pin 3	gnd + -
Link Out gain	0 dB

Genelec Document D0053R001a. Copyright Genelec Oy 12.2003. All data subject to change without prior notice

GENELEC®

International enquiries:
Genelec, Oivitie 5
FIN-74100, Iisalmi, Finland
Phone +358 17 83 881
Fax +358 17 812 267
Email genelec@genelec.com

In the U.S. please contact
Genelec, Inc., 7 Tech Circle
Natick, MA 01760
Phone +1 508 652 0900
Fax +1 508 652 0909
Email genelec.usa@genelec.com

www.genelec.com