

HT320BC

Operating Manual

Genelec HT320BC
Active 3-Way Speaker

GENELEC®





Genelec HT320BC Active 3-Way Speaker

System

The Genelec HT320BC is a dedicated center channel loudspeaker for three channel (LCR) and Surround systems. Its compact enclosure has been designed for optimum placement in the limited space above or below a video monitor or screen. The HT320BC is a three-way active loudspeaker including drivers, multiple power amplifiers and active crossovers. The amplifiers and crossovers are built into a separate 3U rack mount unit.

The system is designed for room volumes up to 250 m³ / 8800 ft³ with maximum listening distances up to 6.1 - 7.6 meters (20-25 ft). The HT320BC is recommended to be flush mounted into the wall structure, but it can also be used as a free-standing loudspeaker.

The unique Directivity Control Waveguide™ (DCW™) Technology provides excellent stereo imaging and frequency balance even in difficult acoustics environments. The fast, low distortion amplifiers are capable of driving the system to peak output levels in excess of 124 dB SPL at 2 m with program signals. Versatile crossover controls allow for precise matching of the system to different acoustic conditions.

Drivers

The bass frequencies are reproduced by two 250 mm (10") bass drivers loaded with a 110 liter vented box. The -3dB point is 33 Hz and the low frequency response extends down to 29 Hz (-6 dB). The midrange frequencies are reproduced by a proprietary 130 mm (5") direct radiating cone driver loaded with a

DCW™. The high frequency driver is a 25 mm (1") metal dome also loaded by a DCW™. The HT320BC is magnetically shielded in order to minimise interference with video monitors

Crossover filters

The crossover frequencies of the active crossover network are 410 Hz and 3.0 kHz. Special calibrated controls are included in the crossover in order to obtain a uniform frequency balance under different acoustic conditions; the Bass, Midrange and Treble Level controls operate in 1 dB steps. Furthermore, the low frequency Tilt and Roll-Off controls both have four 2 dB steps to allow refined LF response tailoring.

A high-pass filter is included in the LF channel to protect the woofer from subsonic signals. The crossover network is driven by an active balanced input stage fed by a 3 pin XLR. Variable input sensitivity allows for accurate to the signal source output.

Amplifiers

The bass, midrange and treble amplifiers produce 400 W, 120 W and 120 W, respectively of short term power with very low THD and IM distortion values. The negative output impedance of the woofer amplifiers improves acoustic transients. The system incorporates special circuitry for driver overload protection and amplifier thermal protection.

Installation

Each HT320BC loudspeaker is supplied with a separate RAM5 amplifier unit in a 19" 3U

rack mount chassis, four Neutrik Speakon cable connectors, a mains cable and an operating manual. Once unpacked, place the loudspeaker in its required position, aiming the line of the acoustic axis (see figure 1) to the center of the listening area.

The RAM5 amplifier is shipped with a pair of rack ears to provide fitting into a 19" rack and a set of feet for placement on a shelf or table.

Sufficient cooling for the RAM5 amplifier must be ensured. The cooling fan on the amplifier back panel draws air through the filter on the left side panel and blows the warmed air to the space behind the amplifier. The airflow must not be obstructed. Note also that the space behind the amplifier must either be ventilated or sufficiently large to dissipate heat so that the ambient temperature does not rise above 35 degrees Celsius (95°F).

When flush mounting the units it should be noted that the cable connectors require 10 cm (4") of free space behind both the loudspeaker and the amplifier.

Connections

Each system is delivered with two 8-pole and two 4-pole Speakon cable connectors for constructing signal cables of desired length.

Measure the required lengths of 8-pole and 4-pole cable and secure the connectors on them pin to pin. See Table 2 for recommended cable thicknesses. The whole cable should have an outside diameter of 8 to 20 mm (5/16" to 13/16") to fit in the Speakon connector.

Speaker mounting position	Bass roll-off	Bass tilt	Bass level	Midrange level	Treble level
Free field anechoic response	None	None	None	None	None
In a corner	-2 dB	-2 dB	-2 dB	None	None
Flush mounted in a wall structure	None	None	-4 dB	None	None

Table 1. Suggested tone control settings in some typical situations

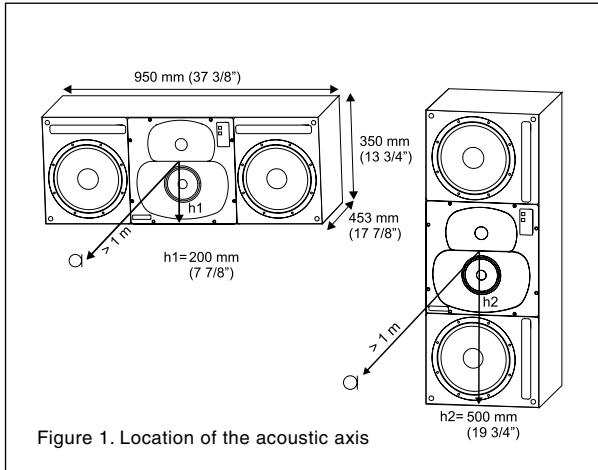

Figure 1. Location of the acoustic axis

Alternatively, pre-terminated lengths of cable are available from Genelec.

Be sure not to mix the amplifier/loudspeaker pairs when installing multiple loudspeakers at the same time. Each amplifier and loudspeaker delivered together are marked with the same identification number and calibrated together for optimal performance.

Audio input is made via a 10 kOhm balanced XLR connector, but unbalanced leads may be used as long as pin 3 is grounded to pin 1 of the XLR. Once connection has been made, the loudspeakers are ready to be powered up.

Access to the front panel controls

The decorative front panel of the amplifier is held in place by guide pins and two magnets. To remove the panel, pull it straight out.

Setting the input sensitivity

Adjustment of the input sensitivity of each loudspeaker can be made to match that of the signal source, by use of the input sensitivity control on the amplifier front panel (see figure 2). A small screwdriver is needed for the adjustment. The manufacturer default setting for this control is -6 dBu (fully clockwise) which gives an SPL of 100 dB @ 1 m

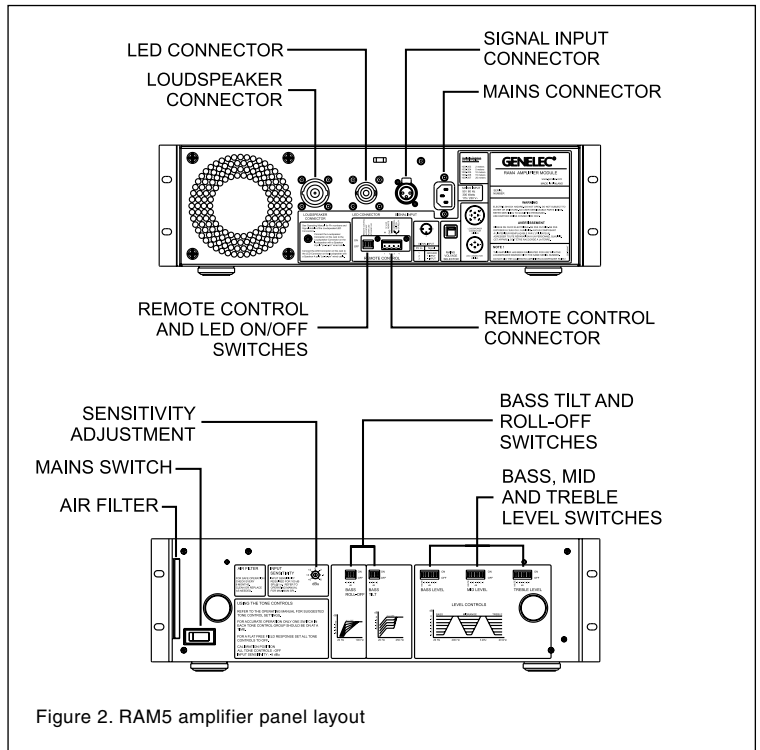

Figure 2. RAM5 amplifier panel layout

Cable gauge	Max. length
2,0 mm ² (14 AWG)	30 m (100 ft)
3,3 mm ² (12 AWG)	40 m (130 ft)
5,3 mm ² (10 AWG)	60 m (200 ft)

Table 2. Recommended cable thicknesses for different lengths of cable

with -6 dBu input level. Note that to get the full output level of 120 dB SPL, an input level of +14 dBu is needed at this setting.

Autostart and remote control

The HT320BC is equipped with an "Autostart" function, which automatically turns the amplifier to "standby" mode if an input signal has not been detected for approximately thirty minutes, and back to "on" mode when the signal returns. The function can be deactivated by turning the "AUTOSTART" dip switch on the amplifier back panel to "OFF". A three-colour LED on the loudspeaker indicates the amplifier status: green for "on" and yellow for "standby".

The amplifier mode can also be switched by a remote control unit connected to the respective inputs on the amplifier back panel. Two pairs of connectors are provided, 1 and 2 for a 12 V DC type remote control, and 3 and 4 for an external switch or relay type con-

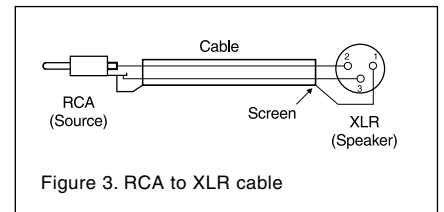

Figure 3. RCA to XLR cable

rol. Do not connect two remote controls to the loudspeaker at the same time. Activate the function by turning the "REMOTE CONTROL" dip switch on the amplifier panel to "ON". Note that the remote control function overrides the "autostart" dip switch function.

Setting the tone controls

The acoustic response of the system may also have to be adjusted to match the acoustic environment. The adjustment is done by setting the five tone control switch groups 'Bass Tilt', 'Bass Roll-Off', 'Bass Level', 'Mid Level' and 'Treble Level' on the amplifier. The manufacturer's default settings for these controls are 'All Off' to give a flat anechoic response. See Table 1 for suggested tone control settings in differing acoustic environments. Figure 8 shows the effect of the controls on the anechoic response. Always start adjustment by setting all switches to the 'OFF' position. Then set only one switch to the 'ON' posi-

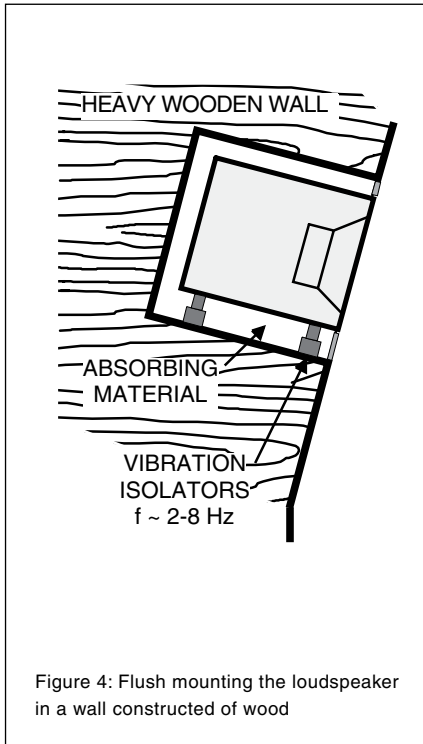

Figure 4: Flush mounting the loudspeaker in a wall constructed of wood

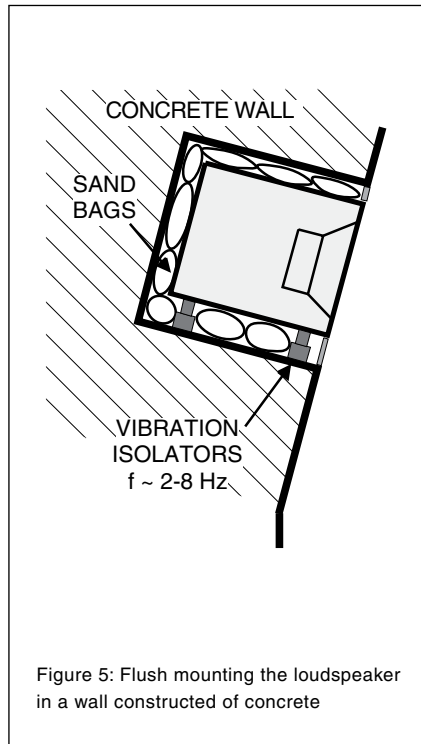

Figure 5: Flush mounting the loudspeaker in a wall constructed of concrete

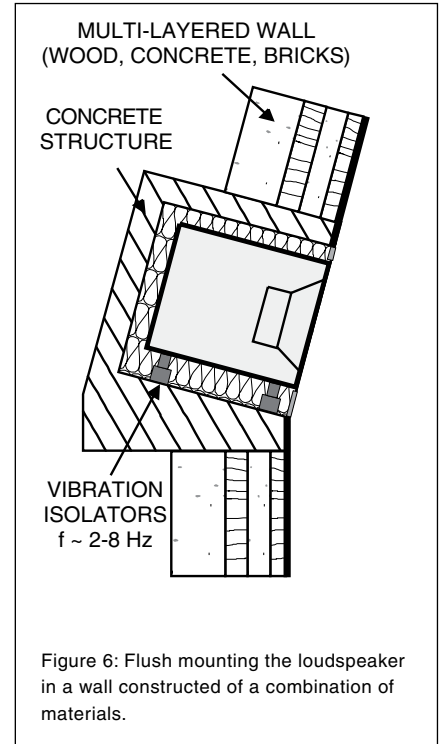

Figure 6: Flush mounting the loudspeaker in a wall constructed of a combination of materials.

tion to select the response curve required. If more than one switch is set to 'ON' (within one switch group) the attenuation value is no longer accurate.

Vertical / horizontal mounting

Genelec HT320BC can be mounted vertically or horizontally. If the loudspeaker's orientation is changed, the DCW™ plate must be rotated so that the treble and mid-range drivers remain vertically aligned with the mid driver at the bottom of the DCW™. Remove the four corner screws of the DCW™ (use a 4 mm Allen key) and pull the plate carefully out without stressing the wires and the gasket. Rotate the plate 90 degrees in the appropriate direction and remount the screws.

Flush mounting

The HT320BC can be used flush mounted into the wall structure, which offers some acoustical benefits. No enclosure edge diffraction will occur, resulting in an improved response, especially at midrange frequencies. Low frequency reflections from the wall behind the loudspeaker can be avoided, which improves the low frequency response and efficiency and allows the loudspeaker to work in half space conditions. In terms of installation and orientation, the loudspeaker's acoustic axis (See figure 1) should point

directly to the listening position. The loudspeaker should be vertically aimed so that the acoustical axis of the loudspeakers meet around ear height at the reference listening position. In the horizontal plane the loudspeakers should be positioned according to the multichannel (ITU-R BS.775-1) placement recommendation.

The ceiling, side walls and especially the rear wall should be acoustically absorbent at low frequencies. The wall in which the loudspeakers are mounted should have a high acoustical mass to properly implement half space radiation at low frequencies and be angled so that the loudspeakers are correctly aimed. However, the loudspeakers should not be mounted too high as this increases the required vertical tilt of the speaker (maximum tilt angle < 20 degrees) and reduces the optimum listening area. Great care should be taken over how the loudspeaker is mounted into the wall. Note the following:

A space 50 to 100 mm (2 to 4") wide can be left around the loudspeaker. Cover the space around the loudspeaker with a facing panel that should be fixed to the wall. Leave a gap of about 5 to 10 mm (¼ to ½") between the loudspeaker and the panel. Fill this gap with a soft rubber gasket to allow for possible movement (see figure 6).

Ensure that the loudspeaker cables can

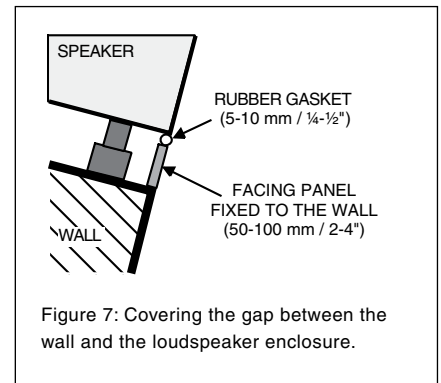

Figure 7: Covering the gap between the wall and the loudspeaker enclosure.

reach the rear of the loudspeaker enclosures.

Regardless of the type of front wall construction the loudspeaker enclosure should be mounted on vibration isolators, with a resonant frequency of 2 to 8 Hz, to prevent vibrations from being transmitted to the wall and impairing the low frequency performance.

If a heavy wooden front wall construction is used, the space around the enclosure should be filled with absorbent mineral wool or foam plastic. The wooden wall structure must be heavily braced to achieve sufficiently high mass and rigidity (see figure 4).

In a wall (e.g. concrete) structure, the space around the enclosure should be filled with either absorbent mineral wool or sand bags (see figure 5).

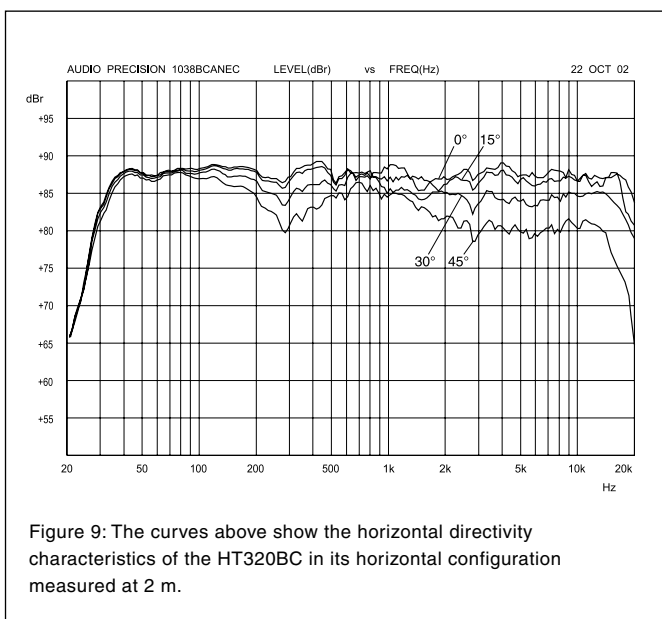
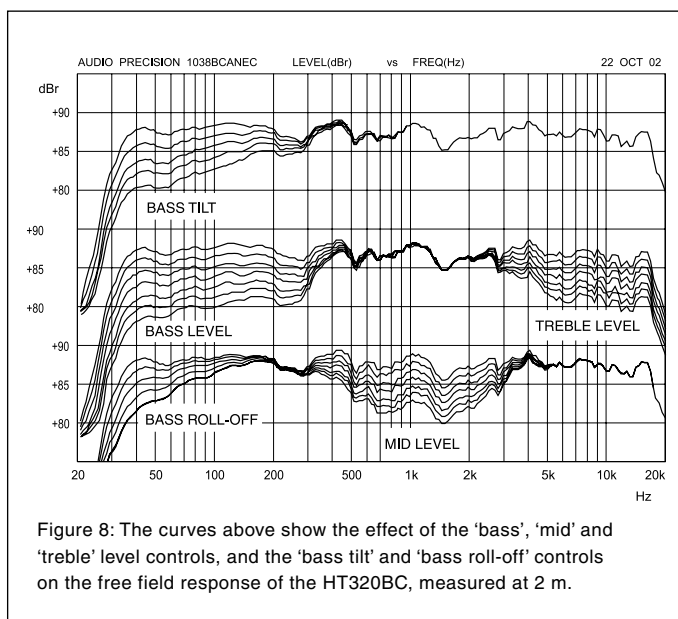

Figure 8: The curves above show the effect of the 'bass', 'mid' and 'treble' level controls, and the 'bass tilt' and 'bass roll-off' controls on the free field response of the HT320BC, measured at 2 m.

Figure 9: The curves above show the horizontal directivity characteristics of the HT320BC in its horizontal configuration measured at 2 m.

The wall can also be constructed of a combination of materials to achieve high acoustic structural mass that will disable low frequency sound propagation and provide high LF sound isolation (see figure 6). Acoustic consultants will be able to provide details and design these structures.

Ensure that the enclosure is flush with the surface of the wall. Discontinuities in the loudspeaker mounting wall will cause diffraction, which leads to inferior frequency response and stereo imaging. So, if a decorative cloth frame is used to cover the wall, make sure that the edges adjacent to the speaker are less than 20 mm (3/4") deep. The cloth must be very thin Tricot or an acoustically transparent material otherwise the high frequency response of the system will be adversely affected. Genelec approved cloth grilles are available.

Mode indicator LED

The Genelec HT320BC is provided with a three-colour indicator LED on the DCW™ panel. When the LED is green, it indicates that the loudspeaker is ready for use. Standby mode is indicated by yellow colour. Amplifier clipping is indicated by a blinking red light and thermal protection mode by a constant red light. If clipping is indicated reduce the signal level so that the LED stops blinking. If the red LED stays on constantly, switch off the loudspeaker and the audio source and let the amplifier cool down. Check that the ventilation around the amplifier is not blocked. There should be a clearance of more than 100 mm (4") between the amplifier face panel and any solid surface at the back. If

the red light does not come off, contact authorised Genelec service.

The LED can be deactivated if you find it disturbing in a darkened room by turning both the "POWER LED" and "STANDBY LED" switches on the amplifier panel to "OFF".

Maintenance

The air filter on the left side of the RAM5 amplifier must be cleaned every six months. Remove the decorative front plate and pull the filter out. Check the filter and replace it with a new one if any damage or brittleness can be found. If the filter is in a good condition, carefully clean it with compressed air.

No other serviceable parts are to be found within the loudspeaker enclosure or the amplifier unit. Any maintenance or repair should only be undertaken by qualified service personnel.

Safety considerations

Although the HT320BC has been designed in accordance with international safety standards, to ensure safe operation and to maintain the instrument under safe operating conditions, the following warnings and cautions must be observed:

1. Servicing and adjustment must only be performed by qualified service personnel. The amplifier must not be opened.
2. Do not use the loudspeaker with an unearthed mains cable or unearthed mains connection as this may lead to

personal injury.

3. This loudspeaker is capable of producing sound pressure levels in excess of 85 dB, which may cause permanent hearing damage.
4. Free flow of air around the amplifier is necessary to maintain sufficient cooling. Do not obstruct airflow around the amplifier.
5. To prevent fire or electric shock, do not expose the unit to water or moisture. Do not place any objects filled with liquid, such as vases on or near the loudspeaker or the amplifier.
6. Note that the amplifier is not completely disconnected from the AC mains service unless the mains cable is removed from the amplifier or the mains outlet.

Accessories

	Order code
Protective grille	1038-409BC

Guarantee

This product is supplied with two year guarantee against manufacturing faults or defects that might alter the performance of the HT320BC unit. Refer to supplier for full sales and guarantee terms.

HT320BC Operating Manual

SYSTEM SPECIFICATIONS	
	HT320BC
Lower cut-off frequency, -3 dB Upper cut-off frequency, -3 dB Free field frequency response of system	<33 Hz >20 kHz 35 Hz - 20 kHz (± 2.5 dB)
Maximum short term sine wave acoustic output on axis in half space, averaged from 100 Hz to 3 kHz	@ 1m >120 dB SPL
Maximum long term RMS acoustic output in same conditions with IEC-weighted noise (limited by driver unit protection circuit)	@ 1m >116 dB SPL
Maximum peak acoustic output per pair in half space with music materia	@ 2m >124 dB
Self generated noise level in free field @ 1m on axis	<15 dB (A weighted)
Harmonic distortion at 95 dB SPL at 1m on axis:	freq. 50...100 Hz <1% freq. >100 Hz <0.5%
Drivers Bass Midrange Treble All drivers are magnetically shielded	2 x 250 mm (10") cone 130 mm (5") cone 25 mm (1") metal dome
Weight Speaker enclosure Amplifier	60 kg (130 lb) 15 kg (33 lb)
Speaker enclosure dimensions Height Width Depth	350 mm (13 3/4") 950 mm (37 3/8") 453 mm (17 7/8")*
Amplifier dimensions Height Width Depth	133 mm (5 1/4") (3 U) 483 mm (19") 350 mm (13 4/5")*

*Without connecting cables. Cable connectors require additional 100 mm (4") of space behind the speaker and the amplifier

AMPLIFIER SECTION	
	HT320BC
Bass amplifier short term output power	2 x 200 W (4 Ohm load)
Midrange amplifier short term output power	120 W (8 Ohm load)
Treble amplifier short term output power	120 W (8 Ohm load)
Long term output power is limited by driver unit protection circuitry.	
Slew rate	80V/ μ s
Amplifier system distortion at nominal output THD SMPTE-IM CCIF-IM DIM 100	<0.05% <0.05% <0.05% <0.05%
Signal to Noise ratio, referred to full output Bass Midrange Treble	>100 dB >100 dB >100 dB
Mains voltage	100, 120, 220 or 230 V
Voltage operating range	nominal $\pm 10\%$
Power consumption Idle Full output	60 W 500 W

CROSSOVER SECTION	
	HT320BC
Input connector XLR female	pin 1 gnd pin 2 + pin 3 -
Input impedance	10 kOhm
Input level for 100 dB SPL output @ 1m	variable from +6 to -6 dBu
Input level for maximum short term output	variable from +26 to +14 dBu for 120 dB SPL @ 1m
Subsonic filter	18 dB/octave below 33 Hz
Ultrasonic filter	12 dB/octave above 25 kHz
Crossover frequency Bass/Mid Mid/Treble	410 Hz 3 kHz
Crossover acoustical slopes	24 - 32 dB/octave
Crossover level control operating range in 1 dB steps Bass Mid Treble	from 0 to -6 dB from 0 to -6 dB from 0 to -6 dB
Bass roll-off control in 2 dB steps	from 0 to -8 dB @ 33 Hz
Bass tilt control in 2 dB steps	from 0 to -8 dB @ 80 Hz

The 'CAL' position is with all tone controls set to 'off' and input sensitivity control to maximum.

www.genelec.com

Genelec Document D0069R001a Copyright Genelec Oy 5.2008. All data subject to change without prior notice

GENELEC®

International enquiries:
Genelec, Olvite 5
FIN-74100, Iisalmi, Finland
Phone +358 17 83881
Fax +358 17 812 267
Email genelec@genelec.com

In the U.S. please contact:
Genelec, Inc., 7 Tech Circle
Natick, MA 01760, USA
Phone +1 508 652 0900
Fax +1 508 652 0909
Email genelec.usa@genelec.com

In China please contact:
Beijing Genelec Audio Co. Ltd.
Jianwai SOHO, Tower 12, Room 2306
39 East 3rd Ring Road
Chaoyang District
Beijing 100022, China
Phone +86 0 5869 7915, Fax +86 10 5869 7914

In Sweden please contact
Genelec Sverige
Ellipsvägen 10B
P.O. Box 5521, S-141 05 Huddinge
Phone +46 8 449 5220
Fax +46 8 708 7071
Email info@genelec.com