

AOW312

Operating Manual
Genelec AOW312
Active On-Wall Loudspeaker

GENELEC®



Genelec AOW312 Active On-Wall Loudspeaker

System

The Genelec AOW312 is a three-way active loudspeaker designed for medium sized, high quality home theater applications. This system excels as side or rear channels when mounted on-wall. It also offers minimum intrusion into designed spaces while providing high sound pressure levels required when employing Genelec's large three-way systems for left, center, and right positions and HTS6 series subwoofer in rooms greater than 260 m³/9000 cu. ft.

Designed as an active loudspeaker system, it contains multiple driver and power amplifiers, active crossover filters and protection circuitry.

The unique Directivity Control Waveguide™ (DCW™) technology developed by Genelec provides extremely stable and accurate imaging and frequency balance even in difficult acoustic environments. Furthermore, versatile and precise crossover controls allow for accurate matching of the loudspeakers systems to different room acoustic conditions.

The AOW312 is fixed to the wall via unique mounting brackets which isolate and suspend the cabinet vertically. The brackets also allow the cabinets to be mounted with a ±15 degree angle offset to the wall to facilitate energy focus at desired listening locations.

All electronics are factory calibrated as

a single unit eliminating the effects of component tolerances and ensuring consistent quality and long term reliability.

Low frequencies are reproduced by a 305 mm (12") bass driver with a low frequency extension to 35 Hz. The 130 mm (5") mid-range cone and 25 mm (1") HF driver are loaded into the proprietary Directivity Control Waveguide as found on the HT312 and HT315 models.

The amplifier unit contains an active crossover, the ideal method for dividing an input signal between the driver units, allowing the overall response of the system to be optimized to an extent impossible with a passive system. Variable input sensitivity as well as XLR line level input connectors provide easy connection and accurate level matching to the preamplifier or surround decoder. The bass, midrange and treble amplifiers of the AOW312 produce 180 W for the low frequency driver and 120 W each for the mid-range and HF drivers.

The amplifiers are designed to operate at very low THD and IM distortion values and are capable of driving the AOW312 to peak output levels in excess of 124 dB SPL at 2 m with music material.

Like all Genelec HT models, the AOW312 incorporates special circuitry for driver overload and amplifier thermal protection, as well as an "Autostart" function for automatic

switching between "Standby" and "On" power modes. A 12 V trigger or external switch or relay type remote control also provides power mode switching.

The 7U remote amplifier modules are supplied with 19" rack-mount metalwork and Neutrik Speakon connectors are provided to facilitate wiring and system connection at customer facilities.

Installation

Once unpacked, place the loudspeaker in its required listening position, taking note of the line of the acoustical axis (see Figure 1). Attach the mounting brackets to the wall with suitable screws for carrying the loudspeaker's weight of 43 kgs (95 lbs). The maximum vertical tilt angle for the loudspeaker cabinet is ±5 degrees.

The mounting brackets are pre-drilled for cabinet alignment angles of -15°, 0° and +15°. If necessary, you can drill new holes to the brackets for exact loudspeaker alignment. The rubber isolators provided must be placed between the brackets and loudspeaker cabinet. See Figures 3 and 4 for details.

It is recommended that the surroundings of the loudspeaker are covered with about 10 cms (4") of rockwool or similar damping material. If the loudspeaker is covered with a cloth, it must be acoustically transparent and a free space of at least 2 cm (3/4") left between the

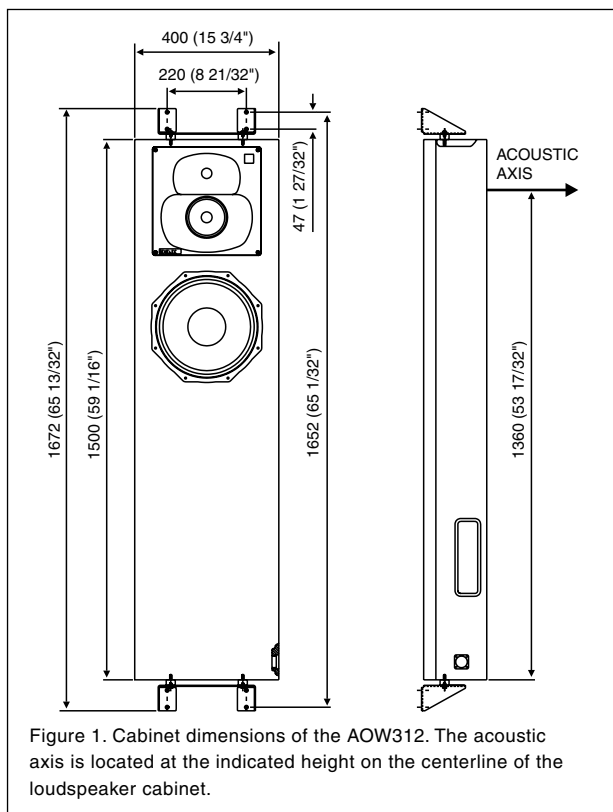

Figure 1. Cabinet dimensions of the AOW312. The acoustic axis is located at the indicated height on the centerline of the loudspeaker cabinet.

front baffle and the cloth. The reflex port of the loudspeaker cabinet is located on the left side of the cabinet (see Figure 1). The airflow from the port must not be obstructed, and a free space of at least 5 cm (2") is required before the port.

Connections

Each loudspeaker is delivered with two Speakon cable connectors. There is one Speakon output on the amplifier and two Speakon cable inputs (one on each side) on the cabinet. Use only one input at any time. The inputs may not be used for daisy-chaining several loudspeakers or connecting two amplifiers to a single loudspeaker.

Measure the required length of cable and solder the connectors on it. Pins 1- and 1+ carry the signal for the tweeter, pins 2- and 2+ for the mid range driver and pins 3- and 3+ for the woofer. Pins 4- and 4+ are not used. See Table 1 below for recommended cable thicknesses. The whole cable should have an outside diameter of 8 to 20 mm (5/16" to

Cable gauge	Max. length
2,0 mm ² (14 AWG)	30 m (100 ft)
3,3 mm ² (12 AWG)	40 m (130 ft)
5,3 mm ² (10 AWG)	60 m (200 ft)

Table 1. Recommended cable thicknesses for different lengths of cable

13/16") to fit in the Speakon connector.

Alternatively, pre-terminated lengths of cable are available from Genelec.

Be sure not to mix the amplifier/loudspeaker pairs when installing multiple loudspeakers at the same time. Each amplifier and loudspeaker delivered in the same box are marked with the same identification number and calibrated together for optimal performance.

Sufficient cooling for the amplifier must be ensured. Leave at least ten centimeters (4 inches) free space above and below the amplifier to ensure cooling. The space adjacent to the amplifier must either be ventilated or sufficiently large to dissipate heat so that the ambient temperature does not rise above 35 degrees Celsius (95°F).

There are no fans in the amplifier unit so it may be mounted in the listening room near the loudspeaker cabinet using a short cable.

Before connecting up, ensure that the mains switch is off. Check that the mains voltage selector is correctly set to your local voltage. Audio input is made via a 10kOhm balanced XLR connector, but unbalanced leads may be used as long as pin 3 is grounded to pin 1 of the XLR. Once connection has been made, the loudspeakers are ready to be powered-up.

Setting the input sensitivity

Adjustment of the input sensitivity of each loudspeaker can be made to match the

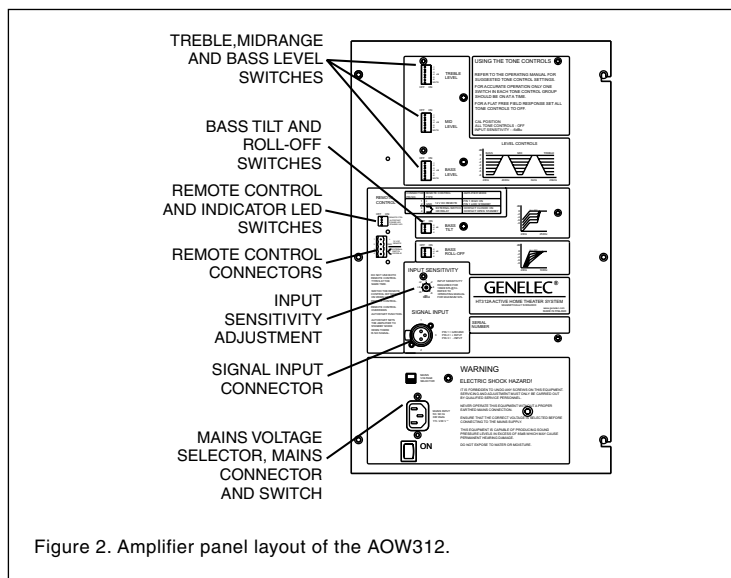

Figure 2. Amplifier panel layout of the AOW312.

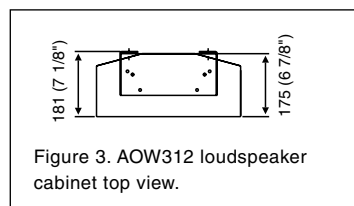

Figure 3. AOW312 loudspeaker cabinet top view.

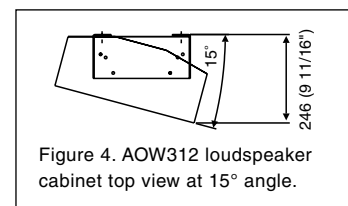

Figure 4. AOW312 loudspeaker cabinet top view at 15° angle.

output of the decoder or other source, by use of the input sensitivity control on the amplifier panel. A small screwdriver is needed for the adjustment. The manufacturer default setting for this control is -6 dBu (fully clockwise) which gives an SPL of 100 dB @1m with a -6 dBu input level. To get the full output level from the AOW312 an input level of +10 dBu is needed at this setting.

Autostart and remote control

The AOW312 is equipped with an "Autostart" function, which automatically turns the amplifier to "standby" mode if an input signal has not been detected for approximately thirty minutes, and back to "on" mode when the signal returns. The function can be deactivated by turning the "AUTOSTART" dip switch to "OFF". A two-colour LED on the amplifier panel indicates the amplifier status: green for "on" and yellow for "standby".

The amplifier mode can also be switched by a remote control unit connected to the respective inputs on the amplifier. Two pairs of connectors are provided, 1 and 2 for a 12 V DC type remote control, and 3 and 4 for an external switch or relay type control. Do not connect two remote controls to the loudspeaker at the same time. Activate the function by turning the "REMOTE CONTROL" dip switch on the amplifier panel to "ON". Note

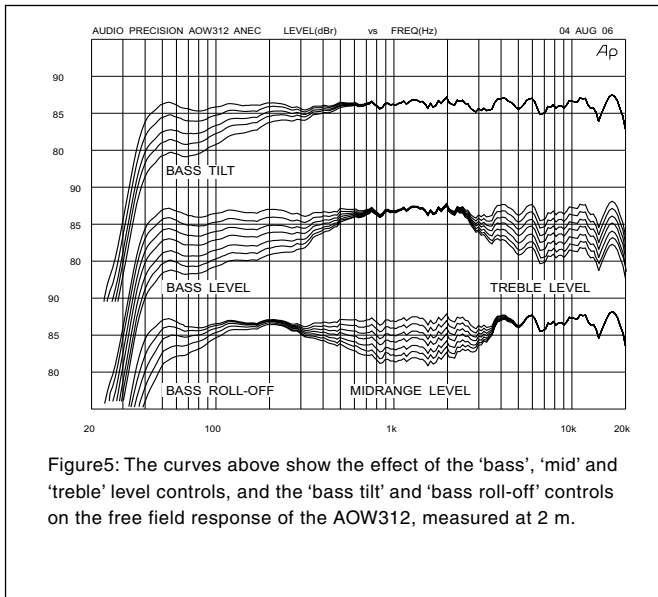

Figure 5: The curves above show the effect of the 'bass', 'mid' and 'treble' level controls, and the 'bass tilt' and 'bass roll-off' controls on the free field response of the AOW312, measured at 2 m.

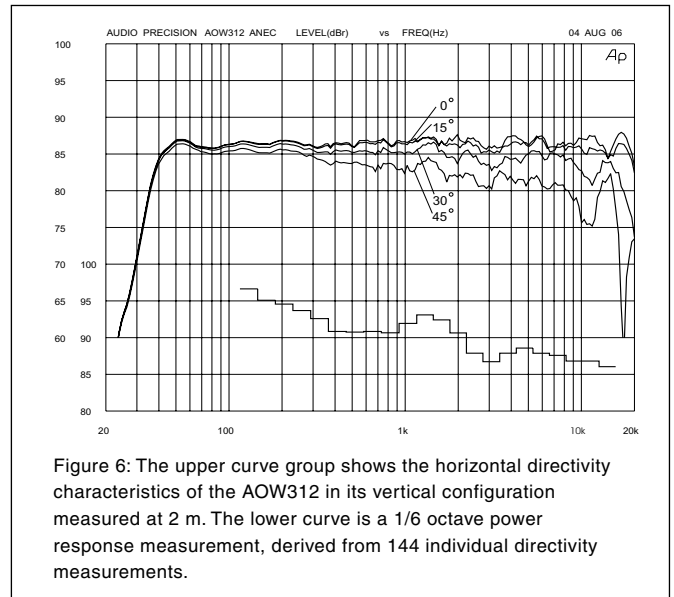

Figure 6: The upper curve group shows the horizontal directivity characteristics of the AOW312 in its vertical configuration measured at 2 m. The lower curve is a 1/6 octave power response measurement, derived from 144 individual directivity measurements.

that the remote control function overrides the "autostart" dip switch function.

Setting the tone controls

The acoustic response of the system should be adjusted to match the acoustic environment. The adjustment is done by setting the five tone control switch groups 'bass tilt', 'bass roll-off', 'bass level', 'mid level' and 'treble level' on the amplifier panel. The manufacturer's default settings for these controls are 'All Off' to give a flat anechoic response. Figure 5 above shows the effect of the controls on the anechoic response. Always start adjustment by setting all switches to the 'OFF' position. Then set only one switch per group to the 'ON' position to select the response curve required. If more than one switch is set to 'ON' (within one switch group) the attenuation value is no longer accurate.

Maintenance

No user serviceable parts are to be found within the loudspeaker cabinet or the amplifier unit. Any maintenance or repair should only be undertaken by qualified service personnel. Ensure that if fuse replacement is required, only fuses of the same voltage and current rating are used. Remember to disconnect the power supply by removal of the mains cable, before fuse replacement.

Safety considerations

Although the AOW312 loudspeaker has been designed in accordance with international safety standards, to ensure safe operation and to maintain the instrument under safe

operating conditions, the following warnings and cautions must be observed:

1. Servicing and adjustment must only be performed by qualified service personnel. The amplifier must not be opened.
2. Do not use the loudspeaker with an unearthed mains cable or unearthed mains connection as this may lead to personal injury.
3. This loudspeaker is capable of producing sound pressure levels in excess of 85 dB, which may cause permanent hearing damage.
4. A free flow of air around the amplifier is necessary to maintain sufficient cooling. Do not obstruct airflow around the amplifier
5. To prevent fire or electric shock, do not expose the unit to water or moisture. Do not place any objects filled with liquid, such as vases on or near the loudspeaker or the amplifier.
6. Note that the amplifier is not completely disconnected from the AC mains service unless the mains cable is removed from the amplifier or the mains outlet.

Guarantee

This product is supplied with a two year guarantee against manufacturing faults or defects that might alter its performance. Refer to supplier for full sales and guarantee terms.

EC Declaration of Conformity

This is to certify that the Genelec AOW312 Active On-Wall Loudspeaker conforms to the following standards:

Safety:
EN / IEC 60065:1998 6th Edition
EMC:
EN 55020 : 2002 + A1 : 2003
EN 55013: (2001)
EN 61000-3-2 (2000)
EN 61000-3-3 (1995)

The product herewith complies with the requirements of The Low Voltage Directive 73/23/EEC, EMC Directive 89/336/EEC and 93/68/EEC

Signed: 
Ilpo Martikainen
Chairman of the Board
Date: 14-August-2006

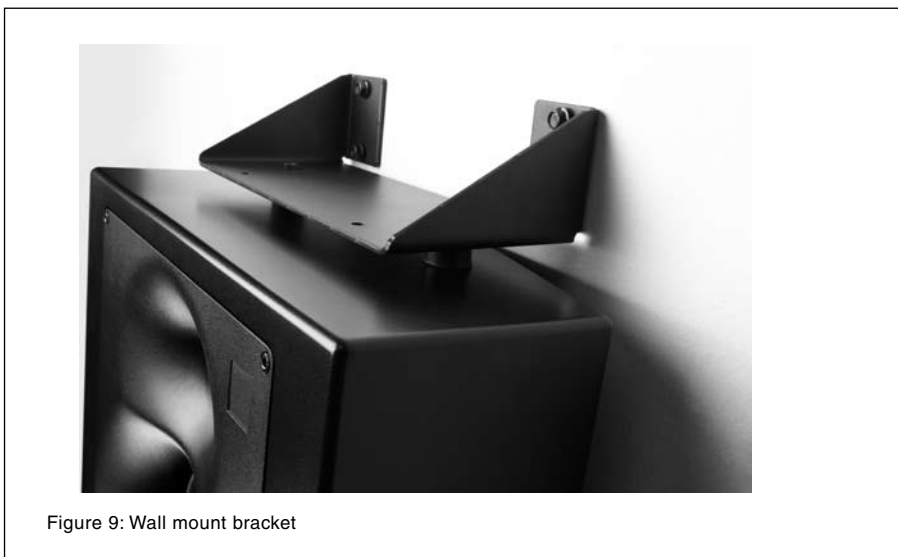
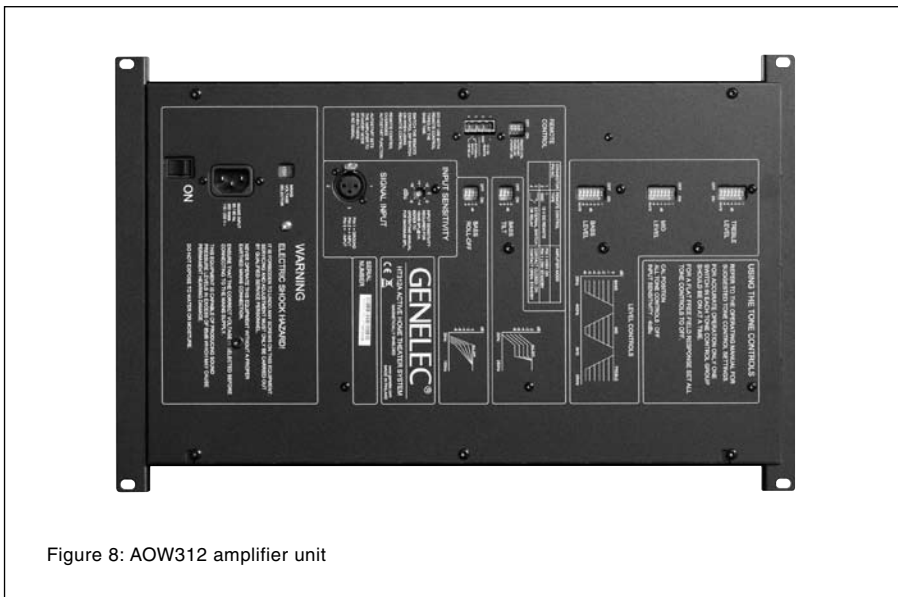
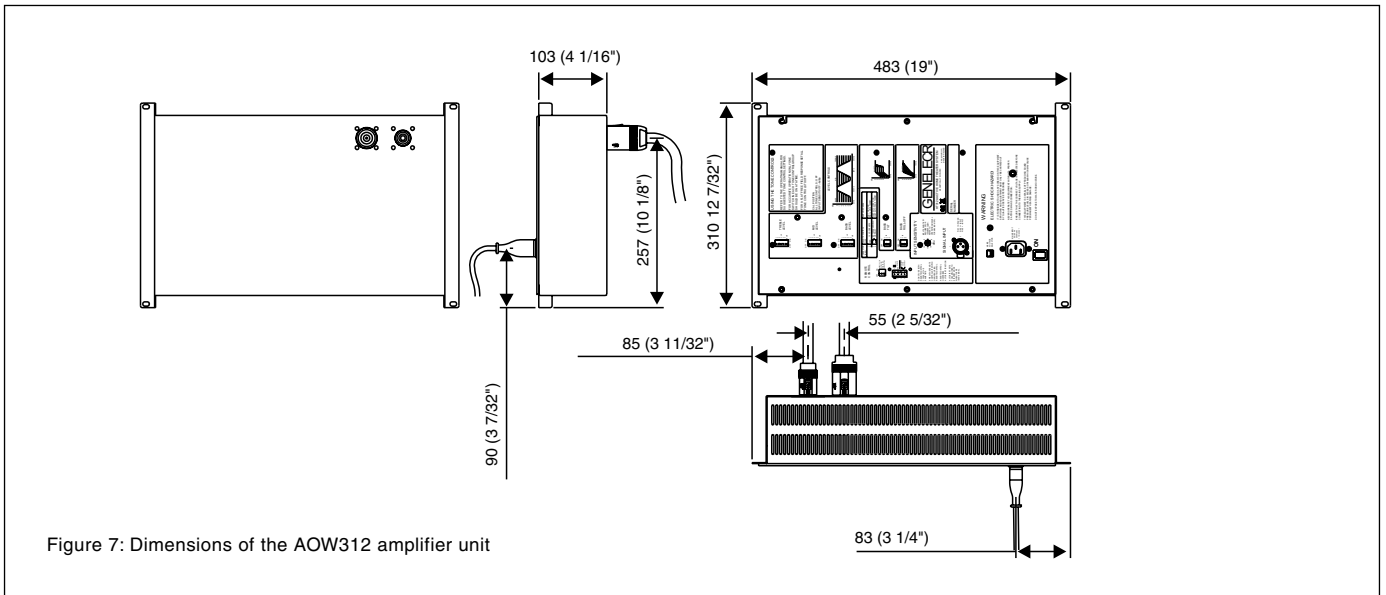

AOW312 Operating Manual

SYSTEM SPECIFICATIONS	
	AOW312
Lower cut-off frequency, -3 dB Upper cut-off frequency, -3 dB Free field frequency response of system	≤35 Hz ≥22 kHz 37 Hz - 21 kHz (±2.5 dB)
Maximum short term sine wave acoustic output on axis in half space, averaged from 100 Hz to 3 kHz	@ 1 m ≥116 dB SPL
Maximum long term RMS acoustic output in same conditions with IEC-weighted noise (limited by driver unit protection circuit)	@ 1 m ≥107 dB SPL
Maximum peak acoustic output per pair above console with music material	@ 2 m ≥123 dB
Self generated noise level in free field @ 2 m on axis	≤15 dB (A weighted)
Harmonic distortion at 95 dB SPL at 1m on axis:	freq. ≤100 Hz <1% freq. >100 Hz <0.5%
Drivers Bass Midrange Treble	305 mm (12") cone 130 mm (5") cone 25 mm (1") metal dome
Weight Loudspeaker Amplifier	43 kg (95 lb) 8 kg (18 lb)
Loudspeaker dimensions Height Width Depth	1500 mm (59 1/16") 400 mm (15 3/4") 175 mm (6 7/8")
Amplifier dimensions Height Width Depth	310 mm (12 7/32") 483 mm (19") 106 mm (4 3/16")*
	*Note that the cable connectors require additional >100 mm (4") space behind the amplifier

AMPLIFIER SECTION	
	AOW312
Bass amplifier short term output power	180 W (4 Ohm load)
Midrange amplifier short term output power with an 8 Ohm load	120 W
Treble amplifier short term output power with an 8 Ohm load	120 W
	Long term output power is limited by driver unit protection circuitry.
Slew rate	80V/μs
Amplifier system distortion at nominal output THD SMPTE-IM CCIF-IM DIM 100	≤0.05% ≤0.05% ≤0.05% ≤0.05%
Signal to Noise ratio, referred to full output Bass Midrange Treble	≥100 dB ≥100 dB ≥100 dB
Mains voltage	100/200V or 115/230V
Voltage operating range	nominal ±10%
Power consumption Idle Full output	50 W 300 W

CROSSOVER SECTION	
	AOW312
Input connector XLR female	pin 1 gnd pin 2 + pin 3 -
Input impedance	10 kOhm
Input level for 100 dB SPL output @ 1m	variable from +6 to -6 dBu
Input level for maximum short term output	variable from +22 to +10 dBu for 116 dB SPL @ 1m
Subsonic filter	18 dB/octave below 35 Hz
Ultrasonic filter	12 dB/octave above 25 kHz
Crossover frequency Bass/Mid Mid/Treble	420 Hz 3.2 kHz
Crossover acoustical slopes	18 - 24 dB/octave
Crossover level control operating range in 1 dB steps Bass Mid Treble	from 0 to -6 dB from 0 to -6 dB from 0 to -6 dB
Bass roll-off control in 2 dB steps	from 0 to -8 dB @35 Hz
Bass tilt control in 2 dB steps	from 0 to -8 dB @80 Hz
	The 'CAL' position is with all tone controls set to 'off' and input sensitivity control to maximum.

GENELEC®

International enquiries:
Genelec, Oulvite 5
FIN-74100, Iisalmi, Finland
Phone +358 17 83881
Fax +358 17 812 267
Email genelec@genelec.com

In the U.S. please contact:
Genelec, Inc., 7 Tech Circle
Natick, MA 01760, USA
Phone +1 508 652 0900
Fax +1 508 652 0909
Email genelec.usa@genelec.com

In China please contact:
Beijing Genelec Audio Co. Ltd.
Jianwai SOHO, Tower 12, Room 2306
39 East 3rd Ring Road
Chaoyang District
Beijing 100022, China
Phone +86 0 5869 7915, Fax +86 10 5869 7914

In Sweden please contact
Genelec Sverige
Ellipsvägen 10B
P.O. Box 5521, S-141 05 Huddinge
Phone +46 8 449 5220
Fax +46 8 708 7071
Email info@genelec.com