

GENELEC®

A C T I V E M O N I T O R I N G

Genelec 1039A
Control Room Monitoring System

Data sheet



1039A Control Room Monitoring System



APPLICATIONS

Main Monitor For Large Control Rooms

SYSTEM

The Genelec 1039A is a very powerful monitor system, designed for large control rooms. It consists of a 320 litres speaker enclosure and a 7U 19" equipment rack which contains active crossovers, three channel power amplifiers and driver protection circuitry. The speakers are designed for flush mounting in the control room wall, although they may be used free standing and can produce peak sound pressure levels in excess of 126 dB.

Bass, midrange and treble controls are included to allow the speakers to be matched to the acoustic conditions in different control rooms. The sensitivity of the system to its environment is minimized by the unique Directivity Control Waveguide (DCW) Technology, which provides excellent stereo imaging and frequency balance even in difficult acoustic situations. The system can be used in both vertical and horizontal orientations by simply rotating the DCW unit.

cellent stereo imaging and frequency balance even in difficult acoustic situations. The system can be used in both vertical and horizontal orientations by simply rotating the DCW unit.

PROTECTION CIRCUITRY

The 1039A amplifier unit contains electronic circuitry which serves to protect the drivers from damage by overload and distortion. These circuits monitor each amplifier channel and automatically reduce the signal level to the driver if an overload condition occurs. In addition the signal levels to all of the drivers in the monitor are reduced by the same amount. This preserves the frequency balance of the monitor. A LED located on the loudspeaker enclosure indicates the condition of this protection circuitry.

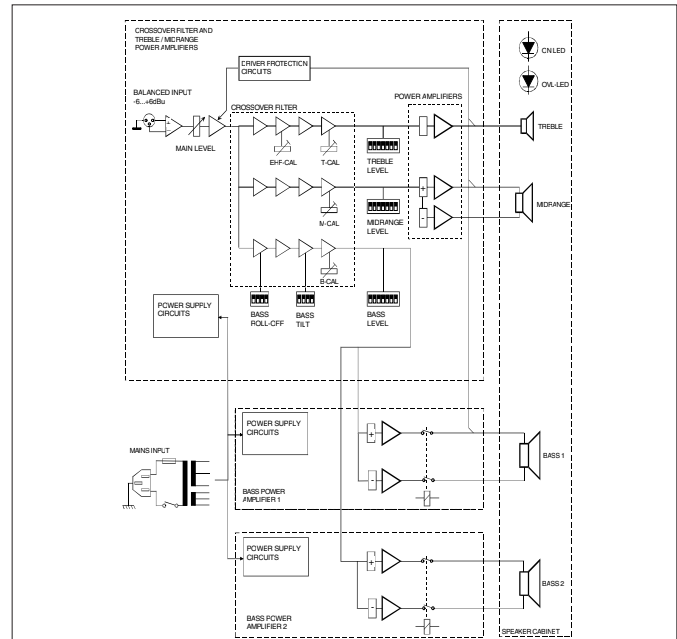

The block diagram showing active crossover filters, power amplifiers and driver units.

AMPLIFIERS

The bass, midrange and treble amplifiers each produce 2x 400W, 350W and 120W of short term power, respectively, with very low harmonic and inter-modulation distortion. The electronics have been carefully designed to ensure the highest subjective sound quality currently possible. Thermal protection is provided for the amplifiers. A standard 10 m cable is supplied for the speaker connection. Longer lengths are available upon special order.

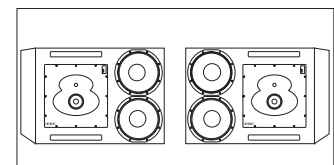

Horizontal mounting

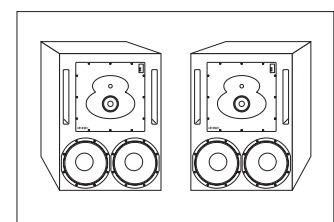

Vertical mounting



The rack mounting amplifiers including crossover and protection.

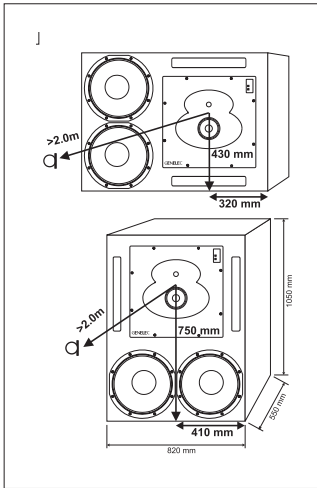

The reference axis lies on the upper midrange driver axis.

CROSSOVER FILTERS

The active crossover network consists of three parallel band pass filters, with crossover frequencies at 400 Hz and 3.2 kHz, and a common balanced input stage. All the filters are aligned for equal phase and group delay characteristics and are acoustically complementary. The filter slopes are 24 dB/octave.

To adjust the balance of the drivers to suit a particular acoustic environment, bass midrange and treble level controls are included, which adjust the output in 1 dB steps. In addition, low frequency roll-off and 'tilt' controls are present, to allow further refinement of the system response.

DRIVERS

Bass frequencies are reproduced by two long throw 385 mm (15") woofers in a vented configuration giving a frequency response extending down to 25 Hz, with the -3 dB point at 29 Hz.

The midrange frequencies are reproduced by a 130 mm (5") high sensitivity direct radiating cone driver and the high frequency driver is a 25 mm (1") metal dome unit, with an upper -3 dB point at 22 kHz. The mid and high frequency drivers have field replaceable diaphragms and are mounted in a DCW for optimized directivity control.

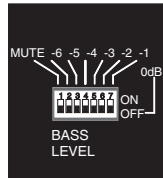

Calibrated crossover control switches. MUTE disconnects the channel for testing.

SOFFIT MOUNTING

Soffit (flush) mounting of a loudspeaker removes problems caused by diffraction effects and reflections from the wall behind it. Diffraction of sound at the loudspeaker cabinet edges degrades the transient response and directional properties, while reflections will cause interference, potentially leading to large dips in the low frequency response. The use of DCW Technology removes the diffraction effects to a large extent. Moreover, the 1039A has versatile frequency response controls to compensate for variations due to different speaker positioning and room loading. This allows it to be either soffit mounted or to be used as a free standing unit without using external equalization, although soffit mounting is highly recommended.

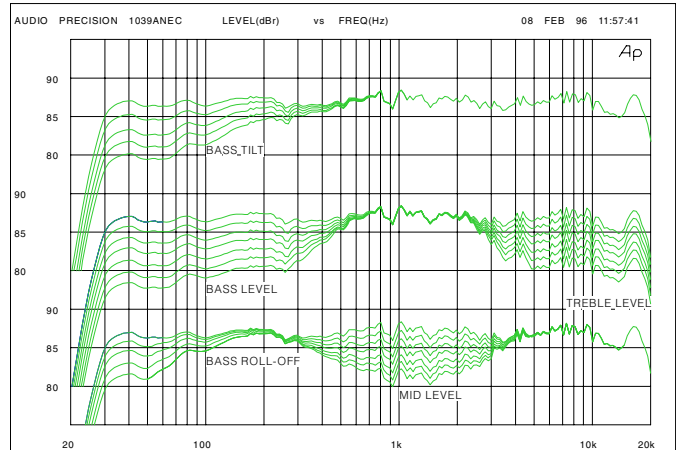

The upper curve group shows the horizontal directivity characteristics of the 1039A in its horizontal configuration measured at 2 m. The lower curve is a 1/6 octave power response measurement, derived from 144 directivity measurements.

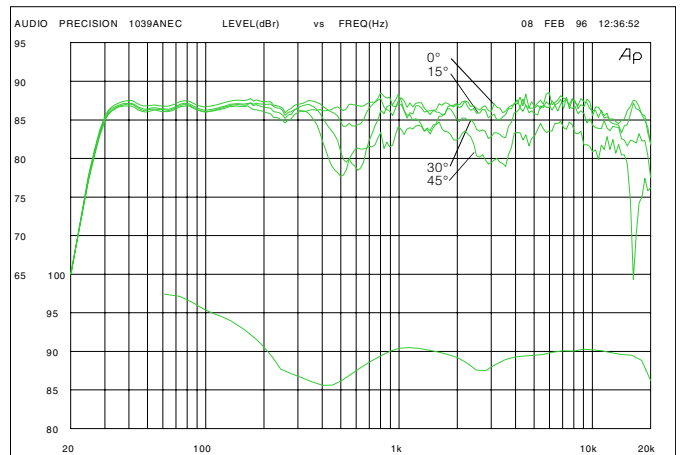

The curves above show the effect of the 'bass', 'mid' and 'treble' level controls, and the 'bass tilt' and 'bass roll-off' controls on the free field response, measured at 2 m.

DCW TECHNOLOGY

The revolutionary Directivity Control Waveguide Technology is a means of greatly improving the performance of a direct radiating multiway loudspeaker under normal listening conditions. One of the basic ideas is to match the performance of the drivers in terms of both frequency response and directivity. This results in smoother frequency response both on and off axis. Also, due to improved directivity control, especially in the midrange frequencies, more direct sound and less reflected sound is received at the listening position. This gives improved stereo imaging and ensures the system is less sensitive to differing control room acoustics than any conventional direct radiator design. The DCW Technology improves the drive unit sen-

sitivity by +2 to +6 dB thus increasing the system maximum sound pressure level.



The high and mid frequency drivers are mounted in a DCW to match their dispersion characteristics. The DCW may be rotated for horizontal or vertical mounting.

GENELEC®

A C T I V E M O N I T O R I N G

1039A SYSTEM SPECIFICATIONS

Lower cut-off frequency, -3 dB: ≤ 29 Hz
 Upper cut-off frequency, -3 dB: ≥ 20 kHz

Free field frequency response of system: 31 Hz - 20 kHz (± 2.5 dB)

Maximum short term sine wave acoustic output on axis in half space, averaged from 100 Hz to 3 kHz: @ 1m ≥ 126 dB SPL

Maximum long term RMS acoustic output in same conditions with IEC-weighted noise (limited by driver unit protection circuit): @ 1m ≥ 120 dB SPL

Maximum peak acoustic output per pair @ 2 m from the engineer with music material: ≥ 126 dB

Self generated noise level in free field @ 2m on axis: ≤ 15 dBA

Harmonic distortion at 100 dB SPL @ 1m on axis:

Freq: 50...200 Hz	$<1\%$
200...10 kHz	$<0.5\%$

Drivers: Bass 2 x 385 mm (15") cone
 Mid 1 x 130 mm (5") cone
 Treble 1 x 25 mm (1") metal dome

Weight: Speaker 115 kg (253 lb)
 Amplifier 30 kg (66 lb)

Speaker dimensions (Horizontal mounting):

Height	820 mm	(32 ⁵ / ₁₆ "
Width	1050 mm	(41 ¹ / ₃ "
Depth	550 mm	(21 ⁵ / ₈ "

Amplifier dimensions:

Height	310 mm	(12 ³ / ₁₆ "
Width	438 mm	(19"
Depth	250 mm	(9 ¹³ / ₁₆ "

AMPLIFIER SECTION

Bass amplifier output power with an 8 Ohm load:
 Short term 2 x 400 W

Mid amplifier output power with a 8 Ohm load:
 Short term 350 W

Treble amplifier output power with an 8 Ohm load:
 Short term 120 W

Long term output power is limited by driver unit protection circuitry.

Slew rate : 80 V/ μ s

Amplifier system distortion at nominal output:

THD	$\leq 0.05\%$
SMPTE-IM	$\leq 0.05\%$
CCIF-IM	$\leq 0.05\%$
DIM 100	$\leq 0.05\%$

Signal to Noise ratio, referred to full output:

Bass	≥ 100 dB
Mid	≥ 100 dB
Treble	≥ 100 dB

Mains voltage: 100/200 or 115/230V

Voltage operating range at 230V setting: 207 - 244 V (-10/+6 %)
 115V setting: 104 - 122 V (-10/+6 %)

Power consumption:

Idle	70 W
Full output	1000 W

CROSSOVER SECTION

Input connector: XLR female pin 1 gnd
 pin 2 +
 pin 3 -

Input impedance: 10 kOhm balanced

Input level for 100 dB SPL output @ 1m: variable from +6 to -6 dBu

Input level for maximum short term output of 126 dB SPL @ 1m: variable from +32 to +20 dBu

Subsonic filter below 25 Hz : 18 dB/octave

Ultrasonic filter above 22 kHz: 12 dB/octave

Crossover frequencies:
 Bass/Mid 400 Hz
 Mid/Treble 3.2 kHz

Crossover acoustical slopes: >24 dB/octave

Level control operating range in 1 dB steps:

Bass	from 0 to -6 dB & MUTE
Mid	from 0 to -6 dB & MUTE
Treble	from 0 to -6 dB & MUTE

Bass roll-off control in 2 dB steps: from 0 to -8 dB @ 29 Hz

Bass tilt control in 2 dB steps: from 0 to -8 dB @ 50 Hz

The 'CAL' position is with all tone controls set to 'off' and input sensitivity control to maximum and corresponds to a maximally flat free field response.

GENELEC®

Genelec Oy, Olvitie 5
 FIN - 74100 IISALMI, FINLAND
 Phone: +358 - 17 - 813 311
 Telefax: +358 - 17 - 812 267
 Web: <http://www.genelec.com>
 E-mail: genelec@genelec.com



Genelec Document BBA39001
 COPYRIGHT GENELEC OY 8/1999
 All data subject to change without prior notice